

PHILIPS

RESPIRONICS

System One

Heated Humidifier

User manual



Instructions for use

Table of Contents

Intended Use.....	2
Warnings	2
Cautions	3
Note	3
Contraindications	3
Symbols Glossary	4
How to Contact Philips Respironics	5
System Overview	5
Available System One Heated Humidifiers.....	6
System Features and Contents	6
Connecting the Therapy Device	7
Connecting the Optional Heated Tubing.....	8
Disconnecting the Optional Heated Tubing	8
Disconnecting the Therapy Device.....	9
Daily Use	9
Cleaning and Disinfection Instructions Summary.....	12
Home Cleaning Instructions	13
Home Disinfection Instructions.....	16
Hospital and Institution Cleaning	17
Hospital and Institution Disinfection	19
Disposal.....	21
Service	21
Traveling with the System	22
Troubleshooting	22
System One Heated Humidifier Specifications.....	25
Heated Tubing Specifications	26
Limited Warranty	27

Intended Use

The System One Heated Humidifier is an accessory for the Philips Respironics REMstar and BiPAP therapy devices to provide moisture to the patient circuit. It is intended for use in spontaneously breathing patients weighing over 30 kg (66 lbs), in the home or hospital/institutional environment, who use mask-applied positive pressure ventilation therapy.



Warning: Use only the cleaning methods outlined in your user manual. Philips is unable to verify the safety or performance of any device if ozone or other unapproved cleaning and disinfection methods are used.

Note: Any damage caused by unapproved ozone cleaning and disinfection methods or other unapproved cleaning and disinfection methods will not be covered by the Philips Limited Warranty.

Warnings

A warning indicates the possibility for injury to the user or the operator.

- Use the humidifier only for its intended use as described in this manual. Use only with Philips Respironics full-face masks, nasal masks, and connectors.
- Periodically inspect the humidifier for signs of wear or damage. Never operate the humidifier if any parts are damaged, if it is not working properly, or if the humidifier has been dropped or mishandled. Do not use the humidifier if the water tank is leaking or damaged in any way. Have any damaged parts replaced before continuing use.
- Periodically inspect the humidifier power cord for signs of wear or damage. If it becomes worn or damaged, contact Philips Respironics or your home care provider for a replacement.
- The humidifier must always be positioned below the breathing circuit connection at the mask and the air outlet on the device. The humidifier must be level for proper operation.
- Allow the humidifier heater plate and water to cool down for approximately 15 minutes before removing the water tank. A burn may result from: touching the heater plate, coming in contact with the heated water, or touching the tank pan.
- This equipment is not suitable for use in the presence of a flammable anesthetic mixture with air or with oxygen or nitrous oxide.
- When installing the water tank, do not allow any water to spill into the humidifier or therapy device.
- If you notice any unexplained changes in the performance of this device, if it is making unusual or harsh sounds, if it has been dropped or mishandled, if water is spilled into the enclosure, or if the enclosure is broken, disconnect the power cord from the therapy device and discontinue use. Contact your home care provider.
- Before cleaning the humidifier, always remove from the therapy device.
- Empty and clean the water tank daily to prevent mold and bacteria growth. Wipe the seal completely.
- Repairs and adjustments must be performed by Philips Respironics-authorized service personnel only. Unauthorized service could cause injury, invalidate the warranty, or result in costly damage.
- Do not use any accessories, detachable parts, and materials not recommended by Philips Respironics. Incompatible parts or accessories can result in degraded performance.

Note: Please see the “Limited Warranty” section of this manual for information on warranty coverage.

Cautions

A caution indicates the possibility of damage to the device.

- Do not place the humidifier directly onto carpet, fabric, or other flammable materials.
- Do not place the device in or on any container that can collect or hold water. Take precautions to protect furniture from water damage.
- Do not fill the water tank above the maximum fill line. Damage to the humidifier or therapy device may occur. If the water tank is overfilled, water may leak out of the tank inlet (located on the back of the tank) when installing the tank lid.
- Never use water from a biologically unsafe source such as a lake, river, stream, or well.
- Philips Respironics recommends using room temperature distilled water in the tank, if available, to prevent mineral build up on the water tank base.
- Do not put any chemicals or additives into the water. Possible airway irritation or damage to the water tank may result.
- Remove the tank, empty all water, and replace the empty tank before transporting the humidifier enclosure.
- Do not attempt to fill the water tank while it is still inside the humidifier.
- To avoid spilling, do not disconnect the humidifier from the therapy device with water in the tank. Remove the water tank from the humidifier before disconnecting the therapy device.
- Do not turn the humidifier on without the water tank installed. The Humidifier setting must remain “off” if there is no water in the water tank.
- The humidifier door must be set in the open position before removing the water tank. Do not remove the water tank without making sure that the humidifier door locks into the open position.
- Do not move the humidifier while the water tank has water in it.
- Use a mild liquid dishwashing detergent only for hand washing.
- Only the hospital and institution cleaning procedures listed in this manual are recommended by Philips Respironics. Use of other cleaning and disinfecting processes, not specified by Philips Respironics, may affect the performance of the product.

Note

This humidifier is an optional accessory to Philips Respironics therapy device and can only operate when it is connected with the therapy. Refer to the therapy device user manual for important EMC information and additional warnings and cautions.

Contraindications

Studies have shown that the following pre-existing conditions may contraindicate the use of CPAP therapy for some patients:



















- Bullous Lung Disease
- Pathologically Low Blood Pressure
- Bypassed Upper Airway
- Pneumothorax
- Pneumocephalus has been reported in a patient using nasal Continuous Positive Airway Pressure. Caution should be used when prescribing CPAP for susceptible patients such as those with: cerebral spinal fluid (CSF) leaks, abnormalities of the cribriform plate, prior history of head trauma, and/or pneumocephalus. (Chest 1989; 96:1425-1426)

The use of positive airway pressure therapy may be temporarily contraindicated if you exhibit signs of a sinus or middle ear infection. Not for use with patients whose upper airways are bypassed. Contact your health care professional if you have any questions concerning your therapy.

Refer to the instructions for use that accompanied your therapy device for any additional contraindications that may be specific to the use of that device.

Symbols Glossary

The following symbols may appear on this device and its packaging. Refer to <http://www.symbols.philips.com> for a description of the symbols used on this device and its packaging.

SYMBOL	DEFINITION	SYMBOL	DEFINITION
	Catalogue number Indicates the manufacturer's catalogue number so the medical device can be identified.		Operator's manual; Consult accompanying instructions for use.
	Serial number Identifies the manufacturer's serial number for the medical device.		Packaging unit To indicate the number of pieces in the package.
	Medical Device Indicates that the item is a medical device.		Authorized Representative in the European Community
	Unique Device Identifier Indicates the Unique Device Identifier information.		Maximum Fill Line
	Manufacturer's number		Warning: Hot Water, Hot Surface
	Humidity limitation Indicates the range of humidity to which the medical device can be safely exposed.		Drip proof equipment Protection against ingress of solid foreign objects ≥ 12.5 mm diameter. Protection against ingress of water with harmful effects dripping (15° tilted).
	Temperature limitation Indicates the storage temperature limits to which the medical device can be safely exposed.		Type BF applied part To identify a type BF applied part complying with IEC 60601-1.
	Manufacturer Indicates the medical device manufacturer.		Separate collection for electrical and electronic equipment per EC Directive 2012/19/EU.
	Date of Manufacture To indicate the date on which a product was manufactured. Country of Manufacturer To indicate the country of manufacture of the product.		MR Unsafe Do not use device in a Magnetic Resonance (MR) environment

How to Contact Philips Respironics

Should you experience trouble with this equipment or require assistance, please contact your home care provider. If you need to contact Philips Respironics directly, contact customer service at 1-800-345-6443 (USA or Canada only) or go to www.respironics.com to find your local customer service contact information

You may also use the following addresses:

Respironics, Inc.
1001 Murry Ridge Lane
Murrysville, PA 15668 USA

System Overview

The System One Heated Humidifier attaches to the therapy device and provides an air outlet port to connect a breathing circuit. The breathing circuit is comprised of patient tubing, a mask, and in some instances a separate exhalation device. The patient tubing can be Respironics heated tubing, 22 mm (non-heated) performance tubing or 15 mm (non-heated) performance tubing. For information related to the mask to be used, including any need for a separate exhalation device, consult the instructions for use that accompany both the mask and therapy device.

The System One Heated Humidifier with Heated Tubing is designed to deliver humidification for added comfort during therapy. This humidification level is controlled through the output of the heated humidifier as well as the temperature of the optional heated tubing. Use of these two accessories allows for a comfortable level of humidity to be maintained at the mask.

The System One Heated Humidifier is comprised of the following components:

- **Heated Humidifier** - The heated humidifier is the primary source of humidification. Humidification is controlled by adjusting the temperature of the heater plate. The heater plate is then used to heat water found in the water tank. This manual includes instructions that explain how to set up and take care of the heated humidifier. For instructions on how to adjust the output of the heated humidifier, refer to the instructions for use that accompanied the therapy device.
- **Water Tank** - The water tank stores the water that will be used by the heated humidifier. This manual includes instructions that cover how to fill up and take care of the water tank.
- **Heated Tubing** - The heated tubing is an optional accessory that is used, along with the heated humidifier, to control the provided humidification. This is accomplished by controlling the temperature of the air in order to ensure that it does not cool down prior to reaching the mask. This manual includes instructions that cover how to connect and take care of the heated tubing. For instructions on how to adjust the temperature of the heated tubing, refer to the instructions for use that accompanied the therapy device.

Available System One Heated Humidifiers

The System One Heated Humidifier is available in the following configurations:

- **Heated Humidifier** - This humidifier provides moisture to the patient circuit. It has a standard air outlet port for use with Philips Respironics 15 and 22mm tubing.
- **Heated Humidifier with Heated Tubing** - This humidifier provides moisture to the patient circuit but also allows for the option of heated tubing. In order to function with the heated tubing, it has a modified air outlet port that includes both a 3-pin connector and a heated tubing locking mechanism. The heated tubing compatible System One Heated Humidifier can be seen in the “Connecting the Optional Heated Tubing” section of this manual.

System Features and Contents

IMPORTANT: Read and understand the entire manual for your therapy device before attempting to use this humidifier.

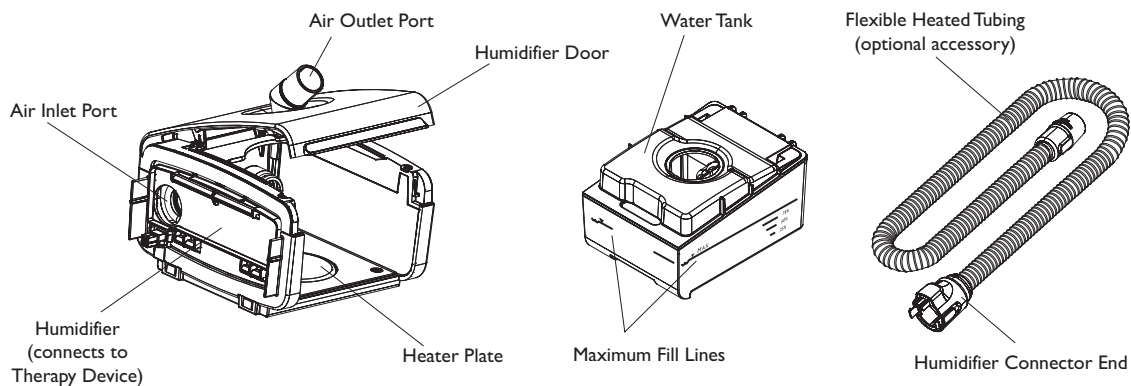

This figure illustrates many of the device features and contents, described in the table below.

ITEM	DESCRIPTION
Humidifier	Connect your therapy device here.
Air Inlet Port	Connects to the outlet port on the therapy device.
Air Outlet Port (conical, 22 mm) (Standard Port shown here)	Connect the patient circuit here. (If you are using the optional heated tubing, this outlet port will look slightly different. Refer to “Connecting the Optional Heated Tubing” section of this manual.)
Heater Plate	Warms the water in the water tank.
Humidifier Door	Open the door to access the water tank.
Humidifier Door Lever	Lift up on the lever to open the humidifier door.
Water Tank	The removable water tank holds the water for humidification.
Maximum Fill Lines	The fill lines indicates the maximum water level for safe operation. (Found on front and both sides of tank.)
Flexible Heated Tubing (optional)	The optional heated tube connects from the humidifier to the patient’s mask.
Humidifier Connector End	Connect this end of the tubing to the humidifier.

Note: This humidifier is specified for use with Philips Respironics REMstar and BiPAP therapy devices only.

Connecting the Therapy Device

1. When using a humidifier, attach the patient circuit to the air outlet port.
2. To connect the therapy device to the humidifier, remove the side cover on the therapy device. Press in the tab on the side cover and pull the cover away from the unit.

Note: Therapy device shown is an example. Actual therapy device may vary.

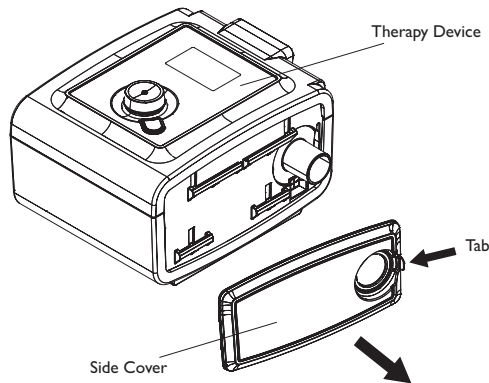

3. Next, line up the components side by side. Make sure that the guides on the humidifier fit into the slots on the therapy device, and the air outlet port on the therapy device fits into the air inlet port on the humidifier.

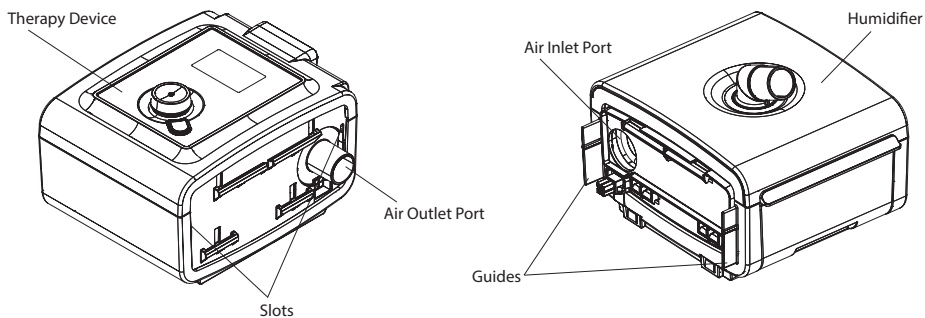

4. While holding both the therapy device and the humidifier, pull the release latch (on the bottom of the humidifier) and press the two units together until they snap into place. Let go of the release latch. Make sure that the therapy device and the humidifier are completely seated against each other.

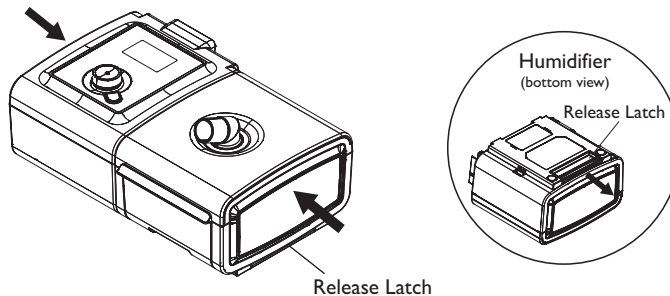

Connecting the Optional Heated Tubing

1. To attach the optional heated tubing to the humidifier, line up the humidifier connector end of the tubing with the Heated Tubing compatible air outlet port on the humidifier. Make sure the 3-pin connector at the top of the tube lines up with the opening at the top of the air outlet port. Press the tubing into place over the air outlet port until the tabs on the side of the tube click into place in the slots on the side of the outlet port.

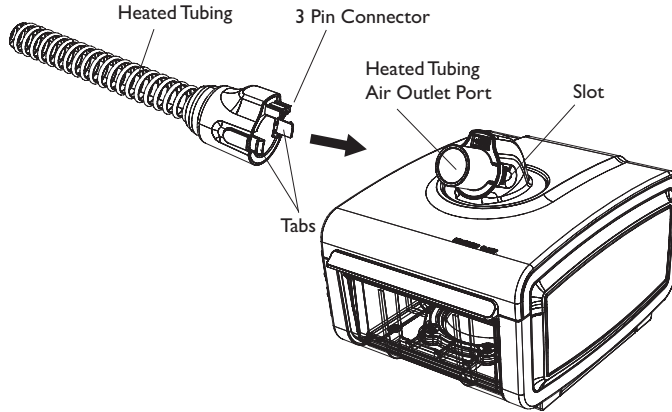

Note: Non-heated Philips Respironics tubing (15 or 22 mm) can still be used with this humidifier with the heated tubing air outlet port. Simply connect the tubing to the air outlet port. Refer to the therapy device manual for setup instructions.

Disconnecting the Optional Heated Tubing

1. To remove the heated tubing, press in the tabs on the side of the tubing connector and pull the tubing away from the outlet port.

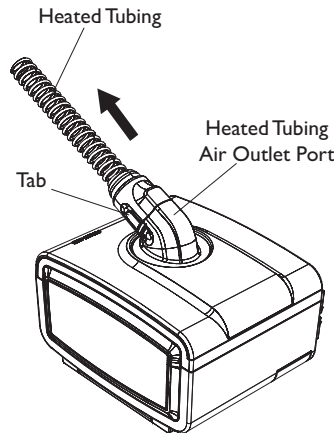

Disconnecting the Therapy Device

CAUTION: To avoid spilling, do not disconnect the humidifier from the therapy device with water in the tank. Remove the water tank from the humidifier before disconnecting the therapy device.

1. Grasp the release latch on the bottom of the humidifier.
2. While holding both the therapy device and the humidifier, pull the release latch and pull the two units apart.

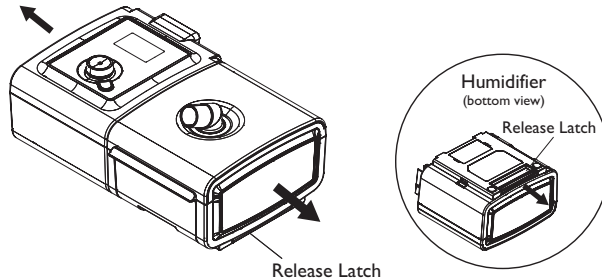

3. If you will be using the therapy device without the humidifier, reattach the side cover to the therapy device.

Daily Use

1. Place the connected therapy device with humidifier on a firm, flat surface lower than your sleeping position.
WARNING: The humidifier must always be positioned below the breathing circuit connection at the mask and the air outlet on the device. The humidifier must be level for proper operation.
CAUTION: Do not place the humidifier directly onto carpet, fabric, or other flammable materials.
CAUTION: Do not place the device in or on any container that can collect or hold water. Take precautions to protect furniture from water damage.
CAUTION: Do not turn the humidifier on without the water tank installed. The Humidifier setting must remain “off” if there is no water in the water tank.
CAUTION: Do not attempt to fill the tank while it is still inside the humidifier.
WARNING: Allow the humidifier heater plate and water to cool down for approximately 15 minutes before removing the water tank. A burn may result from: touching the heater plate, coming in contact with the heated water, or touching the tank pan.
2. Lift up on the release lever to open the humidifier door until it locks in an open position. You will hear a “click” once the door is opened far enough to remain in an open position. Remove the water tank by grasping the front of the tank and sliding it out of the humidifier enclosure.
CAUTION: The humidifier door must be set in the open position before removing the water tank. Do not remove the water tank without making sure that the humidifier door locks into the open position.

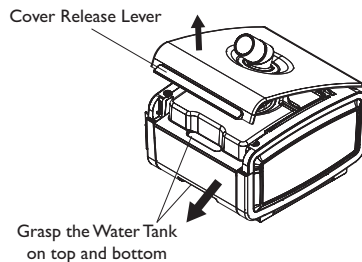

3. Press the tab in the hole on top of the tank in toward the front of the tank. Gently remove the tank lid from the tank base and set aside. Empty any remaining water from the base of the tank.

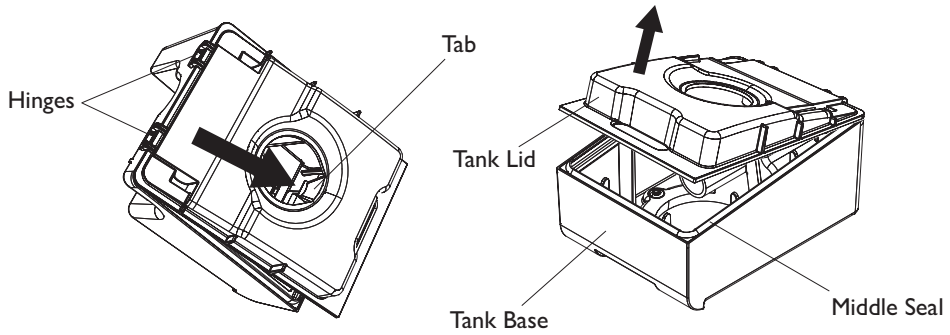

4. Rinse the tank with water. With the water tank sitting on a flat surface, fill it with distilled water (approximately 325 ml) no higher than the maximum fill line located on the front and both sides of the tank.

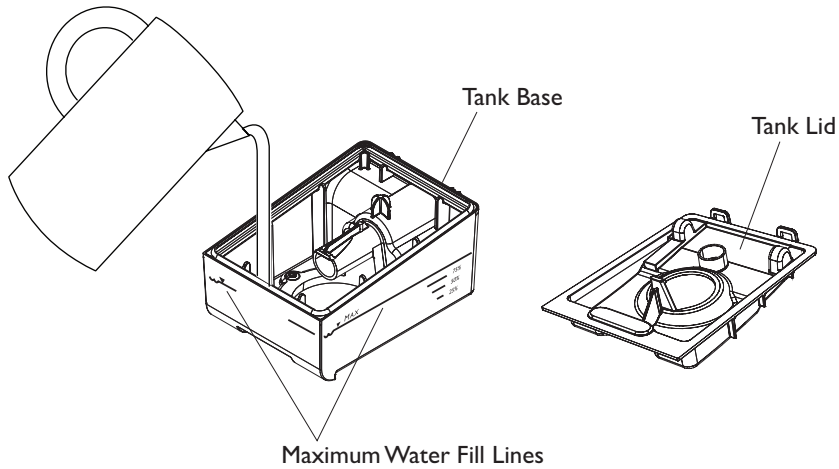

Note: Clean the water tank before first use. Refer to the “Home Cleaning” section in this manual.
CAUTION: Use only room temperature distilled water in the tank. Do not put any chemicals or additives into the water. Possible airway irritation or damage to the water tank may result.
CAUTION: Do not fill the water tank above the maximum fill line. Damage to the humidifier or therapy device may occur. If the water tank is overfilled, water may leak out of the tank inlet (located on the back of the tank) when installing the tank lid.

5. Reassemble the tank by placing the hinges on the tank lid over the 2 tabs on the back of the tank base. Close the lid until the tab on the lid snaps back under the lip in the tank base. Inspect the tank. When it is closed correctly, the lid should be seated completely on the middle seal and it should sit snugly on the tank base so the tab can easily snap back in place.

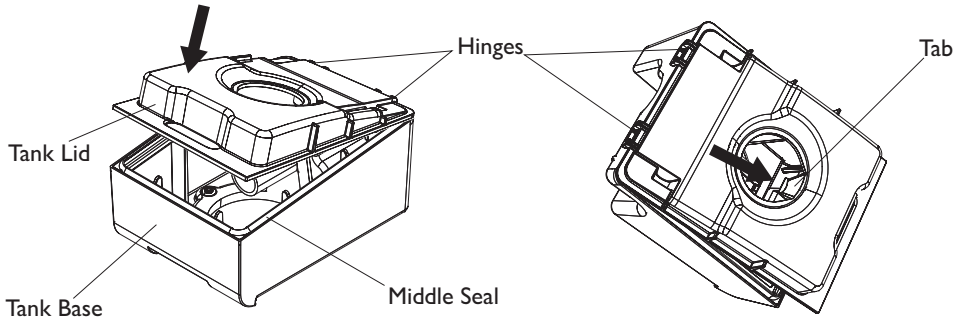

Note: If the lid does not close easily onto the base, separate the two parts, reassemble the tank, and inspect it again.

CAUTION: Do not fill the water tank above the maximum fill line. Damage to the humidifier or therapy device may occur. If the water tank is overfilled, water may leak out of the tank inlet (located on the back of the tank) when installing the tank lid.

6. Slide the water tank back into the humidifier.

WARNING: When installing the tank, do not allow any water to spill into the humidifier or therapy device.

CAUTION: Do not move the humidifier while the water tank has water in it.

7. Plug the power supply cord into the back of the therapy device.
8. Plug the AC power cord into the power supply provided with your therapy device, and then plug the AC power cord into an electrical outlet that is not controlled by a wall switch.

IMPORTANT: You must use the 80W power supply when using the heated tube humidifier with your therapy device. The appropriate power supply can be identified by the  symbol.

9. Attach the flexible tubing from the patient circuit to the humidifier's air outlet port. (If using the optional heated tubing, Refer to "Connecting the Optional Heated Tubing" section of this manual.)

IMPORTANT: Before each use, examine the flexible tubing for any kinks, damage, or debris. If necessary, clean the tubing to remove the debris. Replace any damaged tubing.

10. Turn on the airflow on your device and begin therapy.

Note: For complete instructions on how to turn on the airflow, refer to the manual included with your therapy device.

11. Put on your mask assembly when the air starts to flow.

Note: If you are having trouble with your mask, refer to the instructions included with the mask.

12. Refer to your therapy device manual for complete instructions on how to adjust both the Heated Humidifier and the optional Heated Tubing settings to achieve the desired humidity.

CAUTION: Do not turn the humidifier on without the water tank installed. The Humidifier setting must remain "off" if there is no water in the water tank.

13. Refer to the manual included with your therapy device for instructions to turn off therapy.

Cleaning and Disinfection Instructions Summary

	HOME CLEANING	HOME DISINFECTION	HOSPITAL CLEANING	HOSPITAL DISINFECTION
Humidifier Enclosure (Exterior Surfaces) and Outlet Port Exterior	Wipe with a lint-free cloth dampened with mild liquid dishwashing detergent (e.g. Dawn® Ultra*) and potable water. Frequency: Every 3 days for 5 years (610 cycles maximum)	Wipe with a lint-free cloth dampened with 70% Isopropyl Alcohol. Frequency: Every 3 days for 5 years (610 cycles maximum)	Wipe with a lint-free cloth dampened with mild liquid dishwashing detergent (e.g. Dawn Ultra) and potable water. Frequency: Every 3 days and between patients for 5 years (610 cycles maximum)	Wipe with DisCide® Ultra Towelettes*. Frequency: Every 3 days and between patients for 5 years (610 cycles maximum)
		Wipe with a lint-free cloth dampened with a 10% Bleach Solution (6% Sodium Hypochlorite, 1 to 9 part reduction in potable water). Frequency: Every 3 days for 5 years (610 cycles maximum)		Wipe with a lint-free cloth dampened with 70% Isopropyl Alcohol. Frequency: Every 3 days and between patients for 5 years (610 cycles maximum)
		Wipe with a lint-free cloth dampened with a 10% Bleach Solution (6% Sodium Hypochlorite, 1 to 9 part reduction in potable water). Frequency: Every 3 days for 5 years (610 cycles maximum)		Wipe with a lint-free cloth dampened with a 10% Bleach Solution (6% Sodium Hypochlorite, 1 to 9 part reduction in potable water). Frequency: Every 3 days and between patients for 5 years (610 cycles maximum)
Outlet Port Interior	Wipe with a lint-free cloth dampened with mild liquid dishwashing detergent (e.g. Dawn Ultra) and potable water. Frequency: Daily for 5 years (1830 cycles maximum)	Utilize Disinfection Aid and fill with 70% IPA. Frequency: Every 3 days for 5 years (610 cycles maximum)	Utilize Disinfection Aid and fill with a commercially available enzymatic detergent solution (e.g. Medizime® LF)*. Frequency: Prior to high-level disinfection	Utilize Disinfection Aid and fill with Cidex® OPA* Frequency: Every 3 days and between patients for 5 years (610 cycles maximum)
Humidifier Water Tank and Lid	Immerse and agitate in a solution of mild liquid dishwashing detergent (e.g. Dawn Ultra) and potable water. Frequency: Daily for 1 year (366 cycles maximum)	Immerse and agitate in 70% Isopropyl Alcohol. Frequency: Every 3 days for 1 year (122 cycles maximum)	Immerse and agitate in a commercially available enzymatic detergent solution (e.g. Medizime LF). Frequency: Prior to high-level disinfection	Immerse in a 75±2°C bath of sterile deionized water for 30 minutes. Frequency: Every 3 days and between patients for 1 year (122 cycles maximum)
				Immerse and agitate in Cidex OPA Frequency: Every 3 days and between patients for 6 months (60 cycles maximum)

* Dawn is a registered trademark of Procter & Gamble.

* Medizime LF is a registered trademark of Medical Chemical Corporation.

* DisCide is a registered trademark of Palmero Healthcare LLC.

* Cidex OPA is a registered trademark of Advanced Sterilization Products, a Johnson & Johnson company.

	HOME CLEANING	HOME DISINFECTION	HOSPITAL CLEANING	HOSPITAL DISINFECTION
Humidifier Door Seal	Immerse and agitate in a solution of mild liquid dishwashing detergent (e.g. Dawn Ultra) and potable water. Frequency: Daily for 1 year (366 cycles maximum)	Immerse and agitate in 70% Isopropyl Alcohol. Frequency: Every 3 days for 1 year (122 cycles maximum)	Immerse and agitate in a commercially available enzymatic detergent solution (e.g. Medizime LF). Frequency: Prior to high-level disinfection	Immerse in a 75±2°C bath of sterile deionized water for 30 minutes. Frequency: Every 3 days and between patients for 1 year (122 cycles maximum)
Dry Box, Dry Box Seal and Inlet Seal	Immerse and agitate in a solution of mild liquid dishwashing detergent (e.g. Dawn Ultra) and potable water. Frequency: Daily for 1 year (366 cycles maximum)	Immerse and agitate in 70% Isopropyl Alcohol. Frequency: Every 3 days for 6 months (60 cycles maximum)	Immerse and agitate in a commercially available enzymatic detergent solution (e.g. Medizime LF). Frequency: Prior to high-level disinfection	Immerse in a 75±2°C bath of sterile deionized water for 30 minutes. Frequency: Every 3 days and between patients for 6 months (60 cycles maximum)
Heated Tubing	Immerse and agitate in a solution of mild liquid dishwashing detergent (e.g. Dawn Ultra) and potable water. Frequency: Every 3 days for 6 months (60 cycles maximum)	Immerse and agitate in 70% Isopropyl Alcohol. Frequency: Every 3 days for 6 months (60 cycles maximum)	Immerse and agitate in a commercially available enzymatic detergent solution (e.g. Medizime LF). Frequency: Prior to high-level disinfection	Immerse in a 75±2°C bath of sterile deionized water for 30 minutes. Frequency: Every 3 days and between patients for 6 months (60 cycles maximum)
				Immerse and agitate in Cidex OPA Frequency: Every 3 days and between patients for 6 months (60 cycles maximum)

Home Cleaning Instructions

Humidifier Enclosure, Heater Plate and Exterior Outlet Port

WARNING: Allow the humidifier heater plate and water to cool down for approximately 15 minutes before removing the water tank. A burn may result from touching the heater plate, coming in contact with the heated water, or touching the tank pan.

WARNING: Before cleaning the humidifier, always remove the humidifier from the therapy device.

1. Open the humidifier lid with the release lever, and then slide the water tank out of the humidifier enclosure.
2. Clean the humidifier enclosure, heater plate and outlet port exterior by wiping it for one minute with a lint-free cloth dampened with a solution of mild liquid dish washing detergent (e.g. Dawn Ultra) and potable water. A ratio of 1 teaspoon of mild liquid dish washing detergent per gallon (3.8 liters) of water is required.
3. Wipe with a new lint-free cloth dampened (not dripping) with potable water for one minute, turning the cloth frequently, to remove all detergent residue. Allow to air dry completely before reconnecting to the therapy device.
4. Inspect the humidifier enclosure for any damage and replace it if necessary.

Outlet Port Interior

1. Clean the humidifier outlet port by using a lint-free cloth dampened with a solution of mild dish washing detergent (e.g. Dawn Ultra) and potable water. A ratio of 1 teaspoon of Dawn per gallon (3.8 liters) of water is required. Insert the cloth approximately 7 cm (2.75 inches) into the outlet opening while cleaning.
2. Wipe with a new lint-free cloth dampened (not dripping) with potable water for one minute, turning the cloth frequently, to remove all detergent residue.
3. Allow to air dry completely before reconnecting to the therapy device.

Water Tank and Lid

Clean the water tank and lid before first use. Hand wash the water tank and lid daily.

1. Turn the humidifier setting to off. Turn the therapy device off. Allow the heater plate and water to cool.

WARNING: Allow the humidifier heater plate and water to cool down for approximately 15 minutes before removing the water tank. A burn may result from touching the heater plate, coming in contact with the heated water, or touching the tank pan.

WARNING: Before cleaning the humidifier, always remove from the therapy device.

WARNING: Empty and clean the water tank weekly to prevent mold and bacteria growth. Wipe the middle seal completely.

2. Open the humidifier lid with the release lever, and then slide the water tank out of the humidifier enclosure.
3. Press the tab in the hole on top of the tank in toward the front of the tank. Gently remove the tank lid from the tank base. Empty any remaining water from the base of the tank.
4. Immerse in a solution of warm potable water and a mild liquid dishwashing detergent (such as Dawn Ultra Dishwashing Liquid) and agitate for one minute. A ratio of 1 teaspoon of mild liquid dishwashing detergent per gallon (3.8 liters) of water is required. Gently wash the middle seal. Rinse the parts with potable water for one minute following hand washing.
5. Allow the parts to completely air dry.
6. Inspect the parts to ensure they are visibly clean. Wipe the parts completely with a damp, lint-free cloth if necessary.
7. Inspect the tank and middle seal for damage. If any part is damaged, replace it.
8. Reassemble the tank by placing the hinges on the tank lid over the 2 tabs on the back of the tank base. Close the lid until the tab on the lid snaps back under the lip in the tank base. Inspect the tank. When it is closed correctly, the lid should be seated completely on the middle seal and it should sit snugly on the tank base so the tab can easily snap back in place.
9. Before using the tank, fill it with distilled water (per the directions in the “Daily Use” section) no higher than the maximum fill line located on the front and sides of the tank.
10. Inspect the water tank for any leaks or damage. If the water tank shows signs of wear or damage, contact your home care provider for a replacement.

Note: If the lid does not close easily onto the base, separate the two parts, reassemble the tank, and inspect it again. Never use the water tank if the tank lid does not fit comfortably on the tank base.

Humidifier Door Seal, Dry Box, Dry Box Seal and Inlet Seal

1. Open the humidifier lid with the release lever, and then slide the water tank out of the humidifier enclosure.
2. Remove the dry box assembly by following the instructions under “Water Tank and Lid, Humidifier Door Seal, Dry Box Seal, Dry Box, Inlet Seal and Heated Tubing”. Be sure to remove the dry box seal and inlet seal from the dry box assembly.
3. Remove the humidifier door seal.
4. Wash the dry box assembly, humidifier door seal, dry box seal and inlet seal by immersing each in a solution of warm potable water and a mild liquid dishwashing detergent (such as Dawn Ultra Dishwashing Liquid) and agitate for one minute. A ratio of 1 teaspoon of mild liquid dishwashing detergent per gallon (3.8 liters) of water is required. Rinse parts with potable water for one minute.
5. Allow them to completely air dry.
6. Inspect the parts to ensure they are visibly clean. Repeat cleaning steps if necessary.
7. Reassemble the dry box seal, inlet seal and humidifier door seal.

Heated Tubing

Clean the heated tubing before first use and weekly.

IMPORTANT: For multi-patient use, complete the steps in the “Hospital and Institution Disinfection” section before each new user.

1. Disconnect the heated tubing from the heated humidifier. Refer to the “Disconnecting the Optional Heated Tubing” section earlier in this manual.
2. Gently wash the heated tubing, including connectors, in a solution of warm potable water and a mild liquid dishwashing detergent (such as Dawn Ultra Dishwashing Liquid) for 1 minute to adequately remove adhering substances from the tubing and connectors. A ratio of 1 teaspoon of mild liquid dishwashing detergent per gallon (3.8 liters) of water is required.
Note: Be sure to clean the entire inner surface of the tube by ensuring it is fully immersed in the detergent solution during gentle agitation by hand.
3. Rinse thoroughly to remove all soap residue from the tube and connectors for 1 minute. Rinse with at least 3 gallons (11.4 liters) of potable water.
4. Allow to air dry completely out of direct sunlight.
5. Visually inspect the tubing for cleanliness, including the connectors. Repeat the cleaning steps if not visually clean.
6. Inspect the heated tubing for damage or wear (cracking, crazing, tears, punctures, etc.). Discard and replace if necessary.

Home Disinfection Instructions

Exterior Humidifier Enclosure and Exterior Air Outlet Port

Complete the following steps to disinfect weekly using 70% Isopropyl Alcohol.

1. Use a lint-free cloth dampened with 70% Isopropyl Alcohol to wipe the alcohol onto the humidifier exterior, thoroughly wetting the surfaces. A separate lint-free cloth dampened with alcohol may be used to wipe down the humidifier air outlet port exterior surface.
2. Keep wet 5 minutes.
3. Pay close attention to all corners and crevices.
4. Wipe with a new lint-free cloth dampened (not dripping) with potable water for one minute, turning the cloth frequently to remove all residue.
5. Allow to air dry completely out of direct sunlight.
6. Visually inspect for cleanliness.
7. Inspect for damage or wear and replace if necessary.

Complete the following steps to disinfect weekly using a 10% bleach solution.

1. Use a lint-free cloth dampened with 10% Chlorine Bleach solution (containing 6% sodium hypochlorite), 1 to 9 part reduction with potable water to wipe the bleach solution onto the humidifier exterior, thoroughly wetting the surfaces. A separate lint-free cloth dampened with 10% Chlorine Bleach solution may be used to wipe down the humidifier air outlet port exterior surface.
2. Keep exterior surfaces wet for 2 minutes.
3. Pay close attention to all corners and crevices.
4. Wipe with a lint-free cloth dampened (not dripping) with potable water for at least one minute, turning the cloth frequently, to remove all bleach residue.
5. Allow the device to air dry completely before plugging in the power cord.
6. Inspect the device, and all circuit parts for damage after disinfection. If any parts are damaged, contact Philips Respironics Customer Service. Replace any damaged parts.

Outlet Port Interior

Complete the following steps to disinfect weekly using 70% Isopropyl Alcohol.

1. Attach the cap end of the disinfection aid to the bottom of the air outlet port (inside of the humidifier lid), and attach the funnel end to the top of the air outlet port.
2. Close the lid and pour the 70% Isopropyl Alcohol into the funnel. Ensure that the inside surface of the air outlet port is completely filled and that the outer edges of the air outlet port are immersed in the 70% Isopropyl Alcohol.

Note: Ensure that the 70% Isopropyl Alcohol completely covers the edge of the air outlet port.

3. Leave the air outlet port immersed for 5 minutes.
4. Empty the Isopropyl Alcohol and then remove the cap and funnel.
5. Reattach the funnel to the bottom of the air outlet port (inside of the humidifier lid).
6. Rinse the air outlet port (including outer edges) by filling with potable water and allow to soak for 1 minute and drain.

Note: After disinfection, the funnel and cap must be rinsed within 10 minutes of use.

Note: Be sure that all surfaces that have contacted the Isopropyl Alcohol (the entire inside surface and outer edges) are rinsed with water.

7. Leave the humidifier lid open and allow to air dry.
8. Reinstall the water tank and the humidifier door seal.
9. Inspect the air outlet port for damage or wear (cracking, crazing, etc.) . Discard and replace the humidifier if inspection of the air outlet port shows damage or wear.

Humidifier Door Seal, Dry Box, Inlet Seal, Dry Box Seal, Water Tank and Tank Lid

The humidifier door seal, dry box, inlet seal, dry box seal, water tank and tank lid may be disinfected every 3 days using 70% Isopropyl Alcohol. Complete the following steps.

1. Remove the water tank by following the instructions for removal under “Home Cleaning Instructions”.
2. Remove the dry box assembly by following the instructions under “Water Tank and Lid, humidifier door seal, Dry Box Seal and Dry Box”. Be sure to remove the dry box seal and inlet seal from the dry box assembly.
3. Remove the humidifier door seal.
4. Immerse separately in 70% Isopropyl Alcohol the water tank, the dry box assembly components including dry box seal and inlet seal, and the humidifier door seal. Immerse with a gentle agitation for five minutes.
5. Rinse with potable water for one minute.
6. Allow to completely air dry away from direct sunlight.
7. Visually inspect for cleanliness.
8. Inspect for damage or wear and replace if necessary.

Hospital and Institution Cleaning

Humidifier Enclosure and Outlet Port Exterior

WARNING: Allow the humidifier heater plate and water to cool down for approximately 15 minutes before removing the water tank. A burn may result from touching the heater plate, coming in contact with the heated water, or touching the tank pan.

WARNING: Before cleaning the humidifier, always remove the humidifier from the therapy device.

1. Open the humidifier lid with the release lever, and then slide the water tank out of the humidifier enclosure.
2. Clean the humidifier enclosure and outlet port exterior and heater plate by wiping it for one minute with a lint-free cloth dampened with a solution of mild liquid dish washing detergent (e.g. Dawn Ultra) and potable water. A ratio of 1 teaspoon of mild liquid dish washing detergent per gallon (3.8 liters) of water is required.
3. Wipe with a new lint-free cloth dampened (not dripping) with potable water for one minute, turning the cloth frequently, to remove all detergent residue. Allow to air dry completely before reconnecting to the therapy device.
4. Inspect the humidifier enclosure for any damage and replace it if necessary.

Outlet Port Interior

CAUTION: Follow all instructions from the manufacturer of the enzymatic detergent. Any deviation from these or the manufacturer’s instructions, including using agents not listed in this guide, may impact the performance of the product. Review all applicable instructions for additional warnings and cautions.

Complete the following steps to clean weekly using a commercially available enzymatic detergent (e.g. Medizime LF®).

1. Attach the cap end of the disinfection aid to the bottom of the air outlet port (inside of the humidifier lid), and attach the funnel end to the top of the air outlet port.
2. Close the lid and pour the enzymatic detergent into the funnel. Ensure that the inside surface of the air outlet port is completely filled and that the outer edges of the air outlet port are immersed in the enzymatic detergent.

Note: Ensure that the enzymatic detergent completely covers the edge of the air outlet port.

3. Leave the air outlet port immersed for 2 to 3 minutes.
4. Empty the enzymatic detergent and then remove the cap and funnel.
5. Reattach the funnel to the bottom of the air outlet port (inside of the humidifier lid).
6. Rinse the air outlet port (including outer edges) by filling with potable water and allow to soak for 1 minute and drain.

Note: After cleaning, the funnel and cap must be rinsed within 10 minutes of use.

Note: Be sure that all surfaces that have contacted the enzymatic detergent (the entire inside surface and outer edges) are rinsed with water.

7. Leave the humidifier lid open and allow to air dry.
8. Reinstall the water tank and the humidifier door seal.
9. Inspect the air outlet port for damage or wear (cracking, crazing, etc.) . Discard and replace the humidifier if inspection of the air outlet port shows damage or wear.

Water Tank and Lid, Humidifier Door Seal, Dry Box Seal, Dry Box, Inlet Seal and Heated Tubing

CAUTION: Follow all instructions from the manufacturer of the cleaning product. Any deviation from these or the manufacturer’s instructions, including using agents not listed in this guide, may impact the performance of the product. Review all applicable instructions for additional warnings and cautions.

Clean the water tank before first use. Clean with a commercially available enzymatic detergent (e.g. Medizime LF) prior to high-level disinfection.

1. While tilting the back humidifier enclosure, use a small flat-edged screwdriver or thumb to press the release at lower back center to remove the humidifier dry box assembly.
2. Remove the dry box seal and inlet seal from the dry box assembly.
3. Immerse components in a commercially available enzymatic detergent (e.g. Medizime LF) for 2 -3 minutes and gently agitate to remove adhering substances.

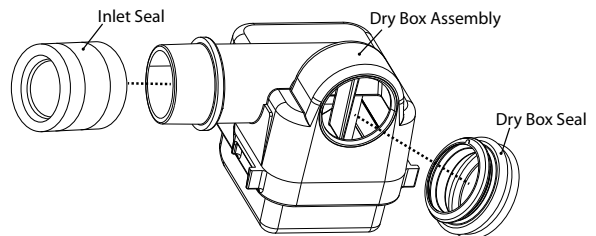

4. Rinse the items separately by immersing each in at least 3 gallons (11.4 liters) of potable water, with gentle agitation by hand for 1 minute.
5. Drain the water from the parts.
6. Allow to air dry completely out of direct sunlight.
7. Inspect for damage or wear (cracking, crazing, tears, punctures, etc). Discard and replace if necessary.
8. Visually inspect for cleanliness. Repeat the cleaning steps if not visually clean.

Hospital and Institution Disinfection

Cleaning of components needs to be completed before disinfection can occur. See Hospital and Institution Cleaning section for instructions.

CAUTION: Only the hospital and institution cleaning and disinfection procedures listed in this manual are recommended by Philips Respironics. Use of other cleaning and disinfection procedures, not specified by Philips Respironics, cannot be guaranteed to maintain the performance or durability of the product. Follow the manufacturer's instructions of the disinfection procedures.

CAUTION: Follow all instructions from the manufacturer of the disinfectant product. Any deviation from these or the manufacturer's instructions, including using agents not listed in this guide, may impact the performance of the product. Review all applicable instructions for additional warnings and cautions.

Water Tank and Lid, Inlet Seal, Humidifier Door Seal, Dry Box Seal, Dry Box and Heated Tubing

Note: When using the below mentioned disinfection processes, the water tank and lid and heated tubing can withstand disinfection every 3 days for 6 months (60 cycles) using Cidex OPA. The water tank and lid and humidifier door seal can withstand thermal disinfection every 3 days for 1 year (122 cycles). The dry box, inlet seal, dry box seal and heated tubing can withstand thermal disinfection every 3 days for 6 months (60 cycles).

1. Clean the device as indicated in the "Hospital and Institution Cleaning: Humidifier Enclosure and Outlet Port Exterior" section of the user manual.
2. Use one of the following methods to disinfect all exterior surfaces of the device.
 - Thermal Disinfection - Immersion in a sterile deionized water bath at 75° C ± 2° C for 30 minutes (water tank and lid, humidifier door seal, dry box seal, inlet seal, dry box and heated tubing)
 - Cidex OPA - Submerge and agitate in undiluted Cidex OPA for 12 minutes at 20° C minimum (water tank and lid and heated tubing only)

Note: When using Cidex OPA, thoroughly rinse with 3 separate 2 gallon (7.6 liter) rinses with warm potable water and air dry completely before the next use.

CAUTION: Follow all instructions from the manufacturer of the disinfectant product. Any deviation from these instructions, the manufacturer's instructions, or agents not listed in this guide may impact the performance of the product. Review all applicable instructions for additional warnings and cautions.

CAUTION: Treat the tank, humidifier door seal and heated tubing as different medical devices when rinsing them with water. For example, the tank, humidifier door seal and heated tubing cannot be rinsed in the same volume of water.

3. Following disinfection using Cidex OPA, separately rinse the dry box assembly, dry box seal, and inlet seal at a minimum of 3 times each in at least 2 gallons (7.6 liters) of water and air dry completely out of direct sunlight.
4. Inspect the components for damage or wear (cracking, crazing, etc). Discard and replace if necessary.
5. Attach the dry box seal and inlet seal to the dry box assembly. Reconnect to the humidifier enclosure by sliding the assembly back into place until it snaps firmly.

Humidifier Enclosure (Exterior Surfaces)

Disinfect the device exterior surface every three days or more often if necessary and between patients.

If using the device on multiple users, the device exterior should be disinfected between patient use as follows:

1. Clean the device as indicated in the “Hospital and Institution Cleaning: Humidifier Enclosure and Outlet Port Exterior” section of the user manual.
2. Use one of the following methods to disinfect all exterior surfaces of the device.

70% Isopropyl Alcohol

- Use a lint-free cloth dampened (not dripping) with Isopropyl Alcohol to thoroughly wipe the exterior of the enclosure.
- Keep the exterior surfaces wet for 5 minutes.

DisCide Ultra Towelettes

- Use DisCide Ultra Towelettes to thoroughly wipe the exterior of the enclosure.
- Keep exterior surfaces wet for 1 minute.

Chlorine Bleach (containing 6% sodium hypochlorite), 1 to 9 part reduction with potable water

- Use a lint-free cloth dampened (not dripping) with the Chlorine Bleach solution to thoroughly wipe the exterior of the enclosure.
 - Keep exterior surfaces wet for 2 minutes.
3. Pay close attention to all corners and crevices of the device exterior surfaces.
 4. Keep wet for amount of time specified for the disinfectant that is being used (see above).
 5. Wipe with a lint-free cloth dampened (not dripping) with potable water for at least one minute, turning the cloth frequently, to remove all detergent residue.
 6. Allow the device to air dry completely before plugging in the power cord.
 7. Inspect the device, and all circuit parts for damage after disinfection. If any parts are damaged, contact Philips Respironics Customer Service. Replace any damaged parts.

Outlet Port Interior

Cleaning of components needs to be completed before disinfection can occur. See Hospital and Institution Cleaning section for instructions.

- Cidex OPA - Soak in undiluted Cidex OPA for 12 minutes at 20° C minimum (water tank and lid and heated tubing only)

Note: When using Cidex OPA, thoroughly rinse with 3 separate 2 gallon (7.6 liter) rinses with warm potable water and air dry completely before the next use.

CAUTION: Follow all instructions from the manufacturer of the disinfection solution. Deviating from these instructions, or the manufacturer's instructions, or using agents not listed in this guide may impact the performance of the product. Review all applicable instructions for additional warnings and cautions. Note that the inside surface of the air outlet port will be immersed once filled.

1. Clean the device as indicated in the "Hospital and Institution Cleaning: Outlet Port Interior" section of the user manual.
2. Attach the cap end of the disinfection aid to the bottom of the air outlet port (inside of the humidifier lid), and attach the funnel end to the top of the air outlet port.
3. Close the lid and pour the disinfection solution into the funnel. Ensure that the inside surface of the air outlet port is completely filled and that the outer edges of the air outlet port are immersed in the disinfection solution.

Note: Ensure that the disinfection solution completely covers the edge of the air outlet port.

4. Leave the air outlet port immersed in undiluted Cidex OPA for 12 minutes at 20° C minimum.
5. Empty the disinfection solution and then remove the cap and funnel.
6. Reattach the funnel to the bottom of the air outlet port (inside of the humidifier lid).
7. Following disinfection, separately rinse the outlet port interior at a minimum of 3 times in at least 2 gallons (7.6 liters) of water and air dry completely out of direct sunlight.

Note: After disinfection, the funnel and cap must be rinsed within 10 minutes of use.

Note: Be sure that all surfaces that have contacted the disinfectant (the entire inside surface and outer edges) are rinsed with water.

8. Leave the humidifier lid open and allow to air dry.
9. Reinstall the water tank and the humidifier door seal.
10. Inspect the air outlet port for damage or wear (cracking, crazing, etc.) . Discard and replace the humidifier if inspection of the air outlet port shows damage or wear.

Disposal

Dispose of this device in accordance with local collections and recycling regulations. For more information, visit www.philips.com/recycling.

Service

The humidifier does not require routine servicing. If any part of the humidifier is worn or damaged, contact Philips Respironics or your home care provider. See the "Troubleshooting" section in this manual for additional information.

Traveling with the System

Packing the System

1. Remove the water tank and empty all water.
2. Put the empty water tank back into the device.
3. Pack your humidifier in your carry-on luggage.

CAUTION: Do not move the humidifier while the water tank has water in it.

When you are traveling, the optional carrying case for your therapy device can be used for carry-on luggage only. The carrying case will not protect the humidifier if it is put through checked baggage.

For your convenience at airport security stations, there is a note on the bottom of the humidifier stating that it is medical equipment. It may be helpful to bring this manual along with you to help security personnel understand the device.

If you are traveling to a country with a line voltage different than the one you are currently using with the therapy device, a different power cord or an international plug adapter may be required to make your power cord compatible with those where you visit. Contact your home care provider for additional information.

Troubleshooting

The table below lists some of the problems you may experience with your humidifier and possible solutions.

PROBLEM	WHY IT HAPPENED	WHAT TO DO
Nothing happens when you apply power to the humidifier.	Loss of AC/DC power or the device is unplugged.	Verify that the humidifier and therapy device are properly plugged in. Make sure the AC power cord is connected correctly to the power supply and the power supply cord is correctly plugged into the wall. If the problem continues to occur, contact your home care provider. Return the humidifier, therapy device, and power supply to your provider to determine if the problem is with the therapy device, humidifier, or power supply.
High Leak	The tubing is not connected correctly and doesn't seal properly.	Remove your mask and tubing and check for kinks or tears. If it is torn or damaged, contact your home care provider or Philips Respironics for replacement tubing and/or mask. If the tubing is not damaged, reattach your tubing, turn on the airflow, and check to make sure you do not still feel air coming out of the port area.
	The therapy device is not seated correctly against the humidifier.	Remove the therapy device from the humidifier and reconnect. Make sure the air inlet port on the humidifier connects securely to the air outlet port on the device. If high leak persists, issue may be caused by a misaligned or damaged seal. Seals are not user-serviceable components. Please contact your home care provider or Philips Respironics.
	The water tank is not properly seated in the humidifier.	Remove the water tank from the humidifier enclosure, and then slide the tank back in the humidifier, making sure it is pushed back as far as it can go. If high leak persists, issue may be caused by a misaligned or damaged seal. Seals are not user-serviceable components. Please contact your home care provider or Philips Respironics.

PROBLEM	WHY IT HAPPENED	WHAT TO DO
The humidifier LED icon on the therapy device is flashing.	There is no communication between the therapy device and the humidifier.	Following the “Daily Use” section earlier in this manual, check the outlet power and verify that the humidifier and therapy device are properly plugged in. Make sure the AC power cord is connected correctly to the therapy device’s power supply. Make sure the AC power cord is correctly plugged into the wall. If the problem continues to occur, contact your home care provider. Return the humidifier, therapy device, and power supply to your provider, to determine if the problem is with the therapy device, humidifier, or power supply.
	The therapy device is not seated properly against the humidifier.	Remove the therapy device from the humidifier and reconnect it. Make sure the air inlet port on the side of the humidifier connects securely to the air outlet port on the side of the device.
	Using the wrong power supply.	If you are using the optional heated tubing, make sure you use the correct 80W power supply.
	Heated tubing is not connected properly or is damaged.	Remove the heated tubing and check for damage. If it is not damaged, reconnect the heated tubing. If the problem continues, contact your home care provider or Philips Respironics.
	The heater plate is not heating.	Check the power connections to the humidifier. If the problem continues, contact your home care provider or Philips Respironics. Note: If the water is not heating, you can temporarily use the humidifier as an unheated pass-over humidifier.
The humidifier is cracked or damaged.	The humidifier was dropped or mishandled.	If the humidifier does not operate properly after being dropped or mishandled, contact your home care provider or Philips Respironics.
The therapy device is operating but the humidifier’s airflow is low or stopped.	The humidifier has an airflow obstruction.	Contact your home care provider. Return the humidifier and power supply to your provider to determine the problem.
The water tank’s middle seal is damaged.	The seal may become damaged during use.	Check the seal for any tears or other damage. If it is damaged, contact your home care provider or Philips Respironics.
Excessive condensation in the tubing.	The humidity level setting is too high.	Reduce the humidity level setting.
	The humidifier is positioned incorrectly.	Verify that the humidifier and therapy device are away from air conditioning equipment.
Heated tube is not warming.	Using the wrong power supply.	Make sure you use the correct 80W power supply. The correct power supply should have the  symbol.
	Heated Tubing setting is set to zero.	Make sure the Heated Tubing setting is not set to zero. Refer to your therapy device’s user manual for instructions.

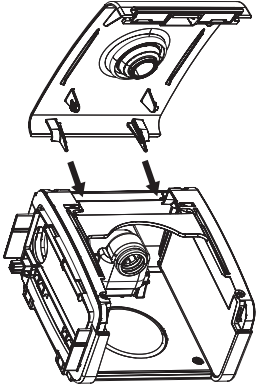
PROBLEM	WHY IT HAPPENED	WHAT TO DO
<p>The humidifier door has been accidentally removed from the humidifier.</p>	<p>Humidifier door was lifted past the locked open position.</p>	<p>The humidifier door can be easily reattached.</p> <p>With the water tank removed, align the hinge side of the door with the back of the humidifier in a fully open position (see figure below). Make sure the hinges are aligned with the grooves of the humidifier. Rotate the door closed. You will need to apply pressure until the door snaps past the locked open position. Verify that the door is working properly.</p>  <p>CAUTION: When using the humidifier with heated tubing, the humidifier has a modified air outlet port that includes a 3-pin connector with wiring leads attached to a terminal connector located at interior back of the humidifier enclosure. If the wiring or leads become disconnected, broken, or worn, do not use the humidifier. Contact your home care provider. If further assistance is needed, contact your home care provider.</p>
<p>The humidifier has fallen off your table or night stand.</p>	<p>The humidifier may not have been properly seated on the night stand, or the placement of the tubing may have caused the device to fall.</p>	<p>Always make sure your humidifier is placed on a hard, flat surface so the rubber feet on the bottom of the humidifier enclosure can adhere to the surface (make sure there is no fabric under the enclosure). The humidifier must be level for proper operation.</p> <p>Also, place the humidifier away from the edge of the night stand or table so it doesn't accidentally get knocked off the table.</p> <p>If the humidifier falls and water gets into the therapy device, drain all water out of the therapy device. Allow it to air dry to make sure it is completely dry before reapplying power.</p> <p>If the placement of the tubing causes the humidifier to fall, make sure that you use proper hose management when setting up your device. Route the tubing behind the bed's headboard.</p> <p>If the humidifier does not operate correctly after falling, contact your home care provider or Philips Respironics.</p>

Note: For information on troubleshooting your therapy device, see the manual included with your therapy device.

System One Heated Humidifier Specifications

Environmental

Operating Temperature: 5° C to 35° C (41° F to 95° F)
Storage Temperature: -20° C to 60° C (-4° F to 140° F)
Relative Humidity (operating & storage): 15 to 95% (non-condensing)
Atmospheric Pressure: 77 to 101 kPa (0 - 2286 m / 0 - 7500 ft)

Physical

Dimensions: 18 x 14 x 10 cm (7" L x 5.5" W x 4" H)
Weight: Approximately 0.89 kg (1.95 lbs.)

Service Life

The expected service life of the System One Heated Humidifier is 5 years.

Water Capacity

325 ml (11 oz.) at recommended water level

Standards Compliance

This device is designed to conform to the following standards:

IEC 60601-1 General Requirements for Safety of Medical Electrical Equipment
EN ISO 8185 General Requirements for Humidification Systems

Electrical

(When the heated humidifier is used with a Philips Respironics therapy device)

AC Power Consumption (with 60W power supply): 100 – 240 VAC, 50/60 Hz, 2.1 A
AC Power Consumption (with 80W power supply): 100 – 240 VAC, 50/60 Hz, 2.0 A
DC Power Consumption: 12 VDC, 6.67 A

Type of Protection Against Electric Shock: Class II Equipment

Degree of Protection Against Electric Shock: Type BF Applied Part

Degree of Protection against Ingress of Water: Drip Proof, IP22

Mode of Operation: Continuous

Electromagnetic Compatibility: The device meets the requirements of EN 60601-1-2, 2nd edition.

Heater Plate

Max Temperature: 75° C (167° F)

Pressure Drop with Humidifier

Max.: 0.8 cm H₂O at 60 LPM flow

Humidity

Humidity_{min} Output: 12 mg H₂O/L

Measured @ max flow, 35° C (95° F), 15% RH.

Maximum Delivered Gas Temperature

With humidifier: 42.3° C (108.1° F)

Without humidifier and inside In-Use bag: 43.3° C (109.9° F)

Note: The above maximum delivered gas temperature values are corrected to a maximum operating temperature of 40° C (104° F).

Humidifier Gas Leakage

Humidifier: Max.: 0.8 cm H₂O at 60 LPM flow

Patient tubing: Max.: 0.8 cm H₂O at 60 LPM flow

Humidifier Run Time Between Water Refills

	CPAP Mode	Bi-level Mode
Continuous Operation:	8 Hours	8 Hours
Temperature:	20° C (68° F)	20° C (68° F)
Humidity:	15% RH	15% RH
Humidifier Setting:	5	5
Patient Pressure:	20 cm H ₂ O	25 cm H ₂ O
Note: Using standard ISO 17025 leak rate.		

Heated Tubing Specifications

Maximum Recommended Pressure

40 cm H₂O

Note: Not all devices will provide the maximum pressure. Refer to your therapy device instructions for use for maximum pressure.

Inner Diameter

15 mm (0.6 in.)

Length

1.83 m (6 ft.)

Heated Tubing Temperature Range

16° C to 32° C (60° F to 89° F)

Heated Tubing Temperature Cut-out

≤ 41° C (≤ 106° F)

Material

Flexible plastic and electrical components

Electrical (Heated tubing is powered by the attached heated humidifier)

Refer to “Electrical” section of System One Heated Humidifier Specifications

Environmental

Refer to “Environmental” section of System One Heated Humidifier Specifications

Limited Warranty

Respironics, Inc., a Philips company (“Philips Respironics”) provides this non-transferable, limited warranty for System One Heated Humidifier (“Product”) to the customer who originally purchased the Product directly from Philips Respironics.

What this warranty covers: Philips Respironics warrants each new Product will be free from defects in materials and workmanship and will perform in accordance with the Product specifications under normal and proper use and maintenance in accordance with applicable instructions, subject to the exclusions below.

How long does this warranty last: two (2) years from the longer of the date of shipment to the purchaser or date of setup by purchaser for the end user, except.

- a. The warranty period for accessories, replacement parts, and disposables including, but not limited to, circuits, tubing, leak devices, exhaust valves, filters and fuses, is ninety (90) days from the date of shipment to the original purchaser.

What this warranty does not cover: This warranty does not apply to any software included with the Product as the software warranty is included in the software license. This warranty does not cover damage or injury whether to the Products, personal property, or persons caused by accident, misuse, abuse, Acts of God, water ingress, unapproved ozone cleaning and disinfection methods, other unapproved cleaning and disinfection methods, repair or alteration by anyone other than Philips Respironics or its authorized service center, failure to operate in accordance with the terms of the operating manual and instructions, lack of reasonable care, the discontinuance of a network (e.g. 2G, 3G, etc.) by a carrier (e.g. ATT, Verizon, etc.), or other defects not related to material or workmanship. This warranty is not transferable. If Philips Respironics finds that a Product returned for service or the issue raised is not covered under this limited warranty, Philips Respironics may charge an evaluation fee and return shipping.

What Philips Respironics will do: If a Product fails to conform to the warranties set forth above during the applicable warranty period, Philips Respironics will repair or replace the Product or refund the original purchase price, in Philips Respironics sole discretion. Philips Respironics may use new or remanufactured assemblies, components, and parts in repair and new or recertified refurbished devices for replacement. The balance of the original warranty period will apply to any Product or component of a Product repaired or replaced under this warranty.

Warranty Disclaimer; Limitation of Liability: EXCEPT AS SET FORTH IN THIS LIMITED WARRANTY, PHILIPS RESPIRONICS MAKES NO WARRANTIES, EXPRESSED OR IMPLIED, STATUTORY OR OTHERWISE, REGARDING THE PRODUCT OR ITS QUALITY OR PERFORMANCE. PHILIPS RESPIRONICS SPECIFICALLY DISCLAIMS THE IMPLIED WARRANTY OF MERCHANTABILITY AND THE IMPLIED WARRANTY OF FITNESS FOR A PARTICULAR PURPOSE. IN NO EVENT WILL PHILIPS RESPIRONICS MAXIMUM LIABILITY UNDER THESE WARRANTIES EXCEED THE ORIGINAL PURCHASE PRICE OR WILL PHILIPS RESPIRONICS BE LIABLE FOR ANY ECONOMIC LOSS, LOSS OF PROFITS, OVERHEAD, OR SPECIAL, INCIDENTAL, OR CONSEQUENTIAL DAMAGES. Repair, replacement, or return of purchase price by Philips Respironics is the original purchaser’s sole and exclusive remedy under this warranty.

This warranty gives you specific legal rights, and you may also have other rights that vary from state to state. Some states do not allow the exclusion or limitation of incidental or consequential damages, so the above exclusion and limitations may not apply to you.

How to get warranty support: Patients contact your local authorized Philips Respironics dealer and dealers contact

1001 Murry Ridge Lane
Murrysville, Pennsylvania 15668-8550
1-724-387-4000

Note: For Australian and New Zealand customers this warranty replaces the warranty included with the user manual.

1. The following statement is provided to a customer who is a consumer under the Australian Consumer Law: Our goods come with guarantees that cannot be excluded under the Australian Consumer Law. You are entitled to a replacement or refund for a major failure and for compensation for any other reasonably foreseeable loss or damage. You are also entitled to have the goods repaired or replaced if the goods fail to be of acceptable quality and the failure does not amount to a major failure. This guarantee applies in addition to other rights and remedies available to the consumer under law.

2. The following statement is provided to a customer who is a consumer under the Consumer Guarantees Act 1993 (NZ): For consumers under the Consumer Guarantees Act 1993 (NZ) who purchase the goods for personal, domestic or household use: Our goods come with guarantees that cannot be excluded under the Consumer Guarantees Act 1993 (NZ).

3. Philips warrants that the products shall be free from defects of workmanship and materials, and will perform in accordance with the product specifications for a period of two (2) years from the date of purchase from an authorised Philips Homecare Provider. This Warranty covers the replacement or repair at the option of Philips, of any product that has a manufacturing or material defect that is not the result of normal wear and tear, or a natural characteristic of the material used. This Warranty is not transferable and does not cover products used for commercial purposes, and it does not apply to any consumable items (including but not limited to filters, masks, tubes and humidifier chambers).

4. The customer is responsible for returning the product to an authorised Philips Homecare Provider, and for collecting the product from the Homecare Provider after repair or replacement, at its own cost. Philips is responsible only for the freight cost of transporting the product between the Homecare Provider and Philips. Philips reserves the right to charge an evaluation and postage fee for any returned product where no problem is found following evaluation.

5. This Warranty does not cover:

- products purchased outside of Australia and New Zealand;
- any damage caused as a result of misuse or abuse, modification, tampering with or alteration of the product, pest infestation, liquid egress into the product, or unapproved ozone cleaning and disinfection methods;
- contamination due to cigarette, pipe, cigar or other smoke;
- failure to follow manufacturer's instruction for use as per the user manual;
- defects that are a consequence of repairs to a product made or attempted by a service provider other than one approved by Philips;
- products that have been subjected to incorrect electrical supply or inconsistent electrical supply or used with inappropriate accessories.

6. This Warranty is not transferrable in the event of any resale or transfer of products.

7. To make a claim under this Warranty, contact your Homecare Provider or Philips:

AUSTRALIA
Philips Electronics Australia Limited
65 Epping Road, North Ryde
NSW 2113 Australia
Tel: 1300 766 488
Email: repairs-src@philips-easyconnect.com

NEW ZEALAND
Philips New Zealand Commercial Ltd
Level 3, 123 Carlton Gore Road
New Market Auckland 1023 New Zealand
Tel: 0800 251 400
Email: repairs-src@philips-easyconnect.com

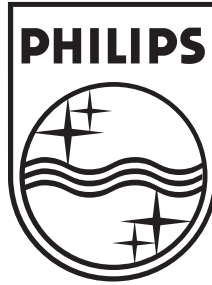

REF 1095654



1095420 R12
JM 05/03/2022
EN-INTL

 Respironics Inc.
1001 Murry Ridge Lane
Murrysville, PA 15668 USA

 Respironics Deutschland GmbH & Co. KG
Gewerbestrasse 17
82211 Herrsching, Germany

